

**ANGLED VIEW**

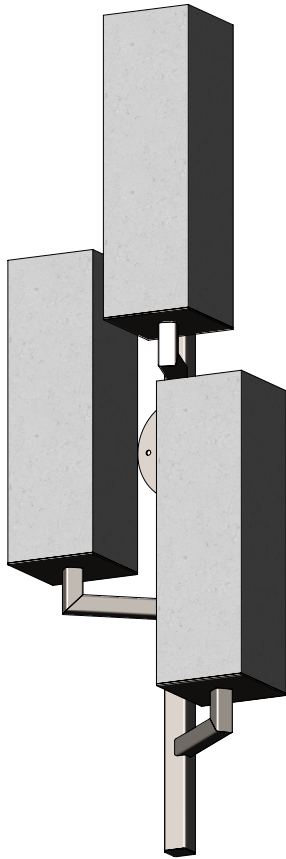

**FRONT VIEW**

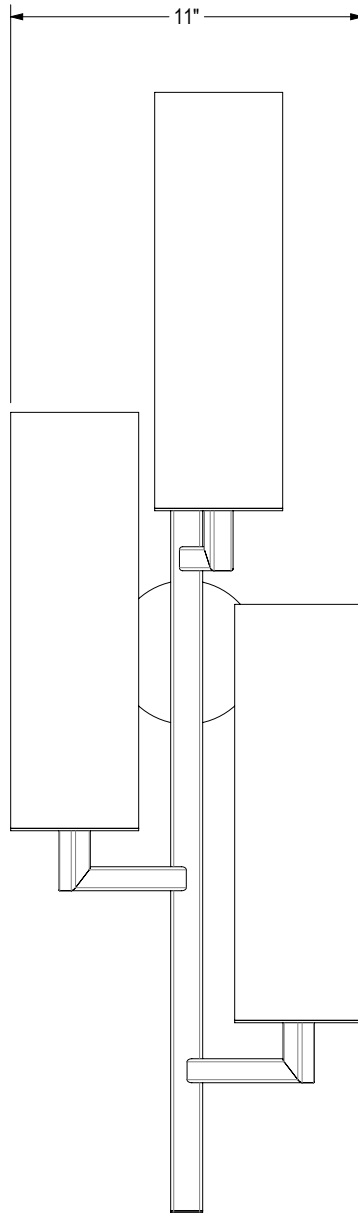

**SIDE VIEW**

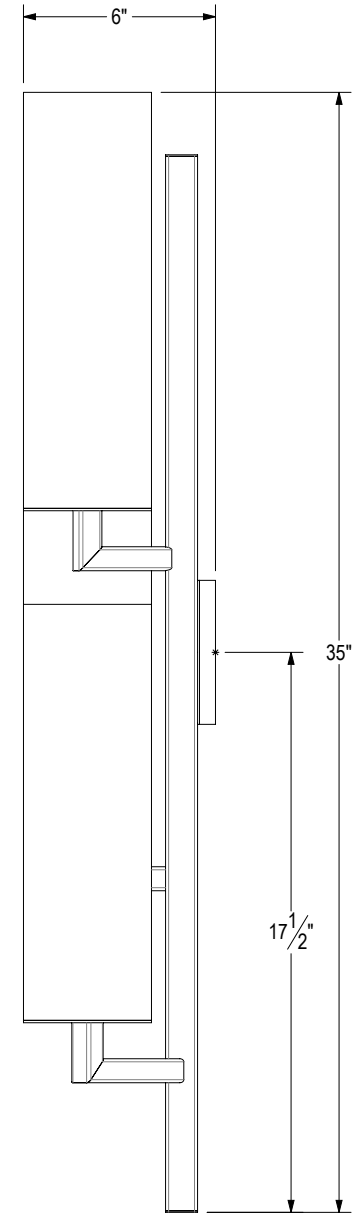

**CST 3949 SC**

A2

Custom 3L Sconce

<b>BACKPLATE:</b>	Custom
<b>CHAIN:</b>	N/A
<b>BASE:</b>	Medium standard
<b>NO. LIGHTS:</b>	3
<b>SHADE:</b>	White onyx Custom
<b>FINISH:</b>	Tier 1 natural black powder coat
<b>WEIGHT:</b>	28 lbs
<b>DRAWING:</b>	Carlos Quezada

10/7/2021

ANGLED VIEW

