

ISOMETRIC VIEW

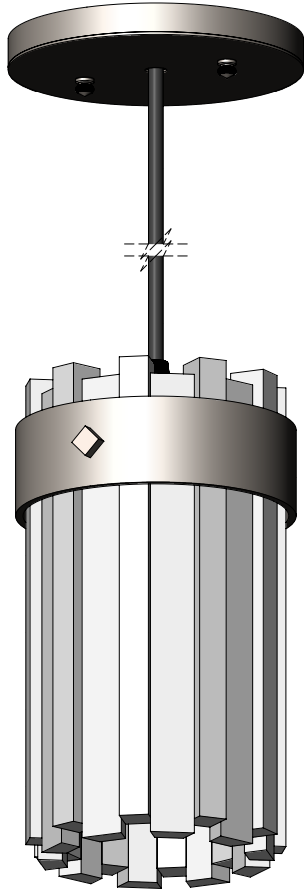

Magnus Onyx PN
Custom Pendant

WEIGHT:	7 lbs
CANOPY:	Custom
CHAIN:	N/A
SHADE:	White onyx
LENS:	N/A
NO. LIGHTS:	1
BASE:	Medium (Ground Porcelain)
FINISH:	Natural Black
ENGINEERED:	Ever Roa

19/01/2021

FRONT VIEW

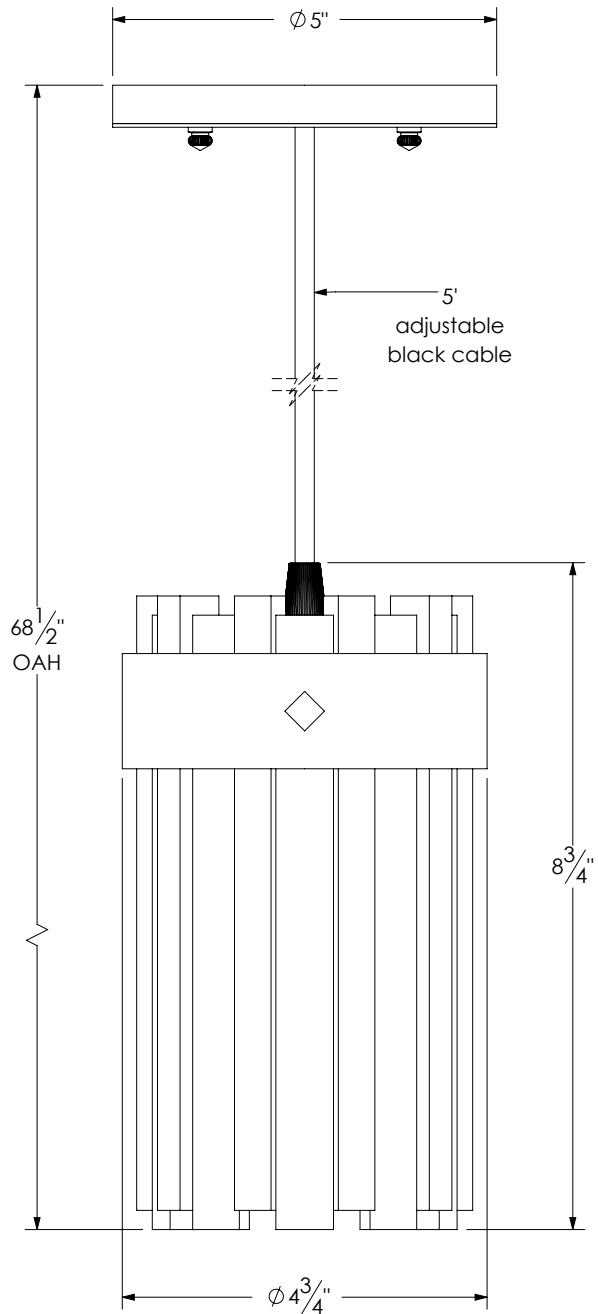

BOTTOM VIEW

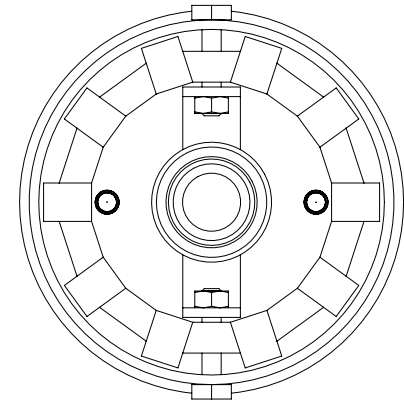

ISOMETRIC VIEW

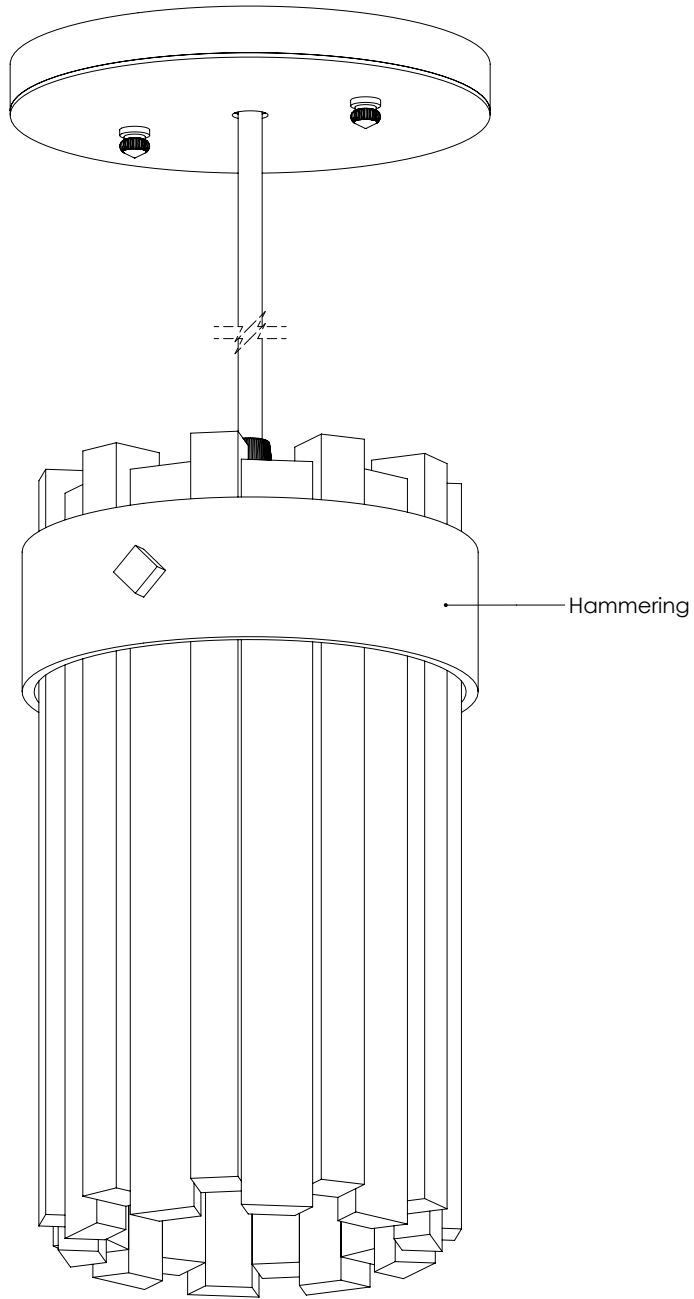

Magnus Onyx PN A

EXPLODED VIEW

