

**PERSPECTIVE VIEW**



**CSTA 0018 CH**  
Custom Chandelier

B2

<b>WEIGHT:</b>	114 lbs
<b>CANOPY:</b>	Heavy Duty
<b>CHAIN:</b>	Loop 5/16"
<b>LENS:</b>	Amber Mica
<b>NO. LIGHTS:</b>	8
<b>BASE:</b>	Medium (Porcelain)
<b>FINISH:</b>	Tier 1 matte black
<b>DRAWING:</b>	Ever Roa

06/12/2021

**FRONT VIEW**

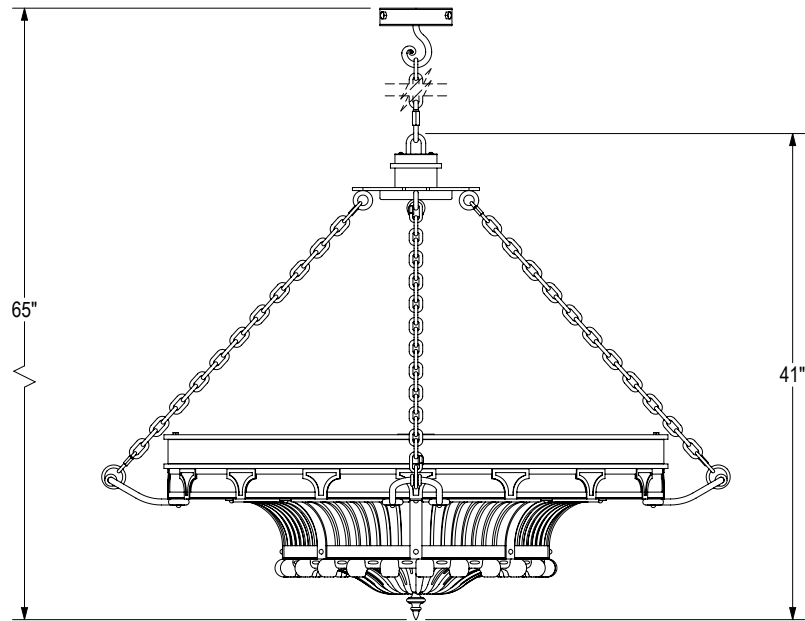

**BOTTOM VIEW**

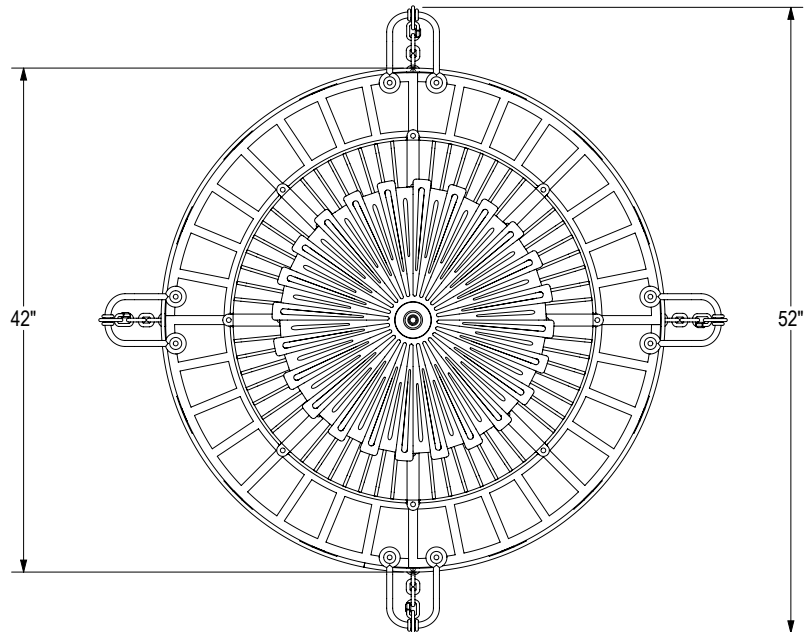

PERSPECTIVE VIEW

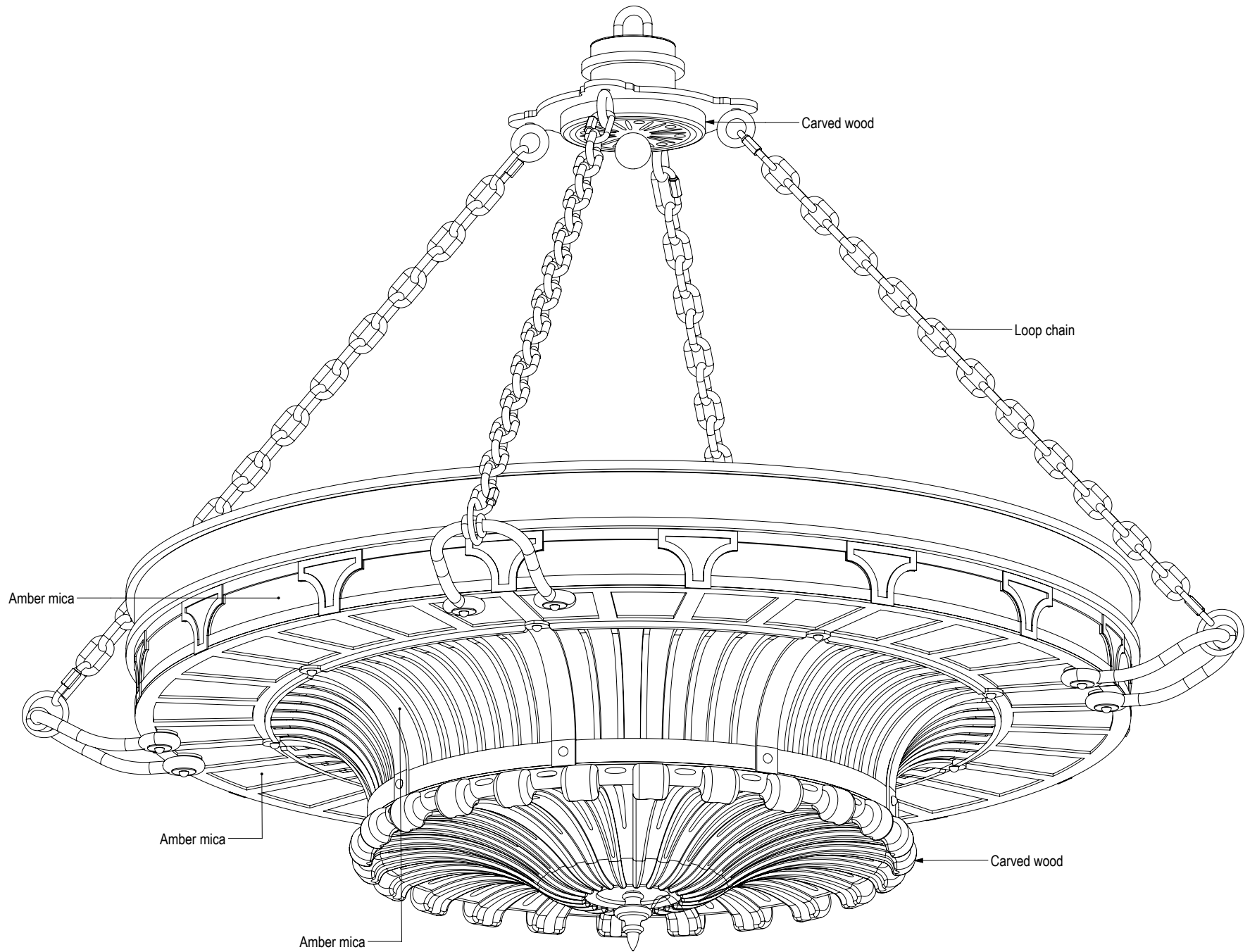

CSTA 0018 CH B

PERSPECTIVE VIEW

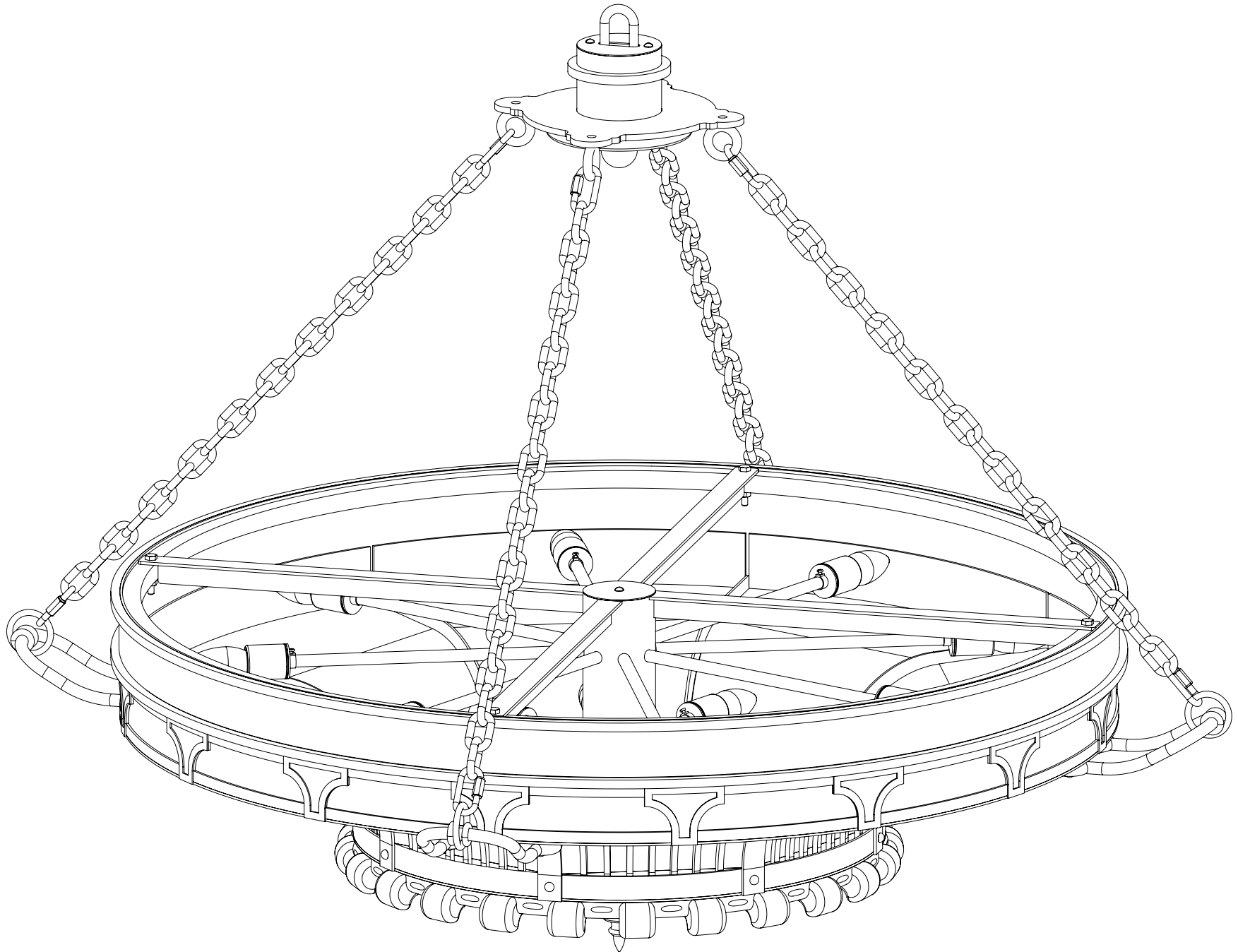

CSTA 0018 CH B

EXPLODED VIEW

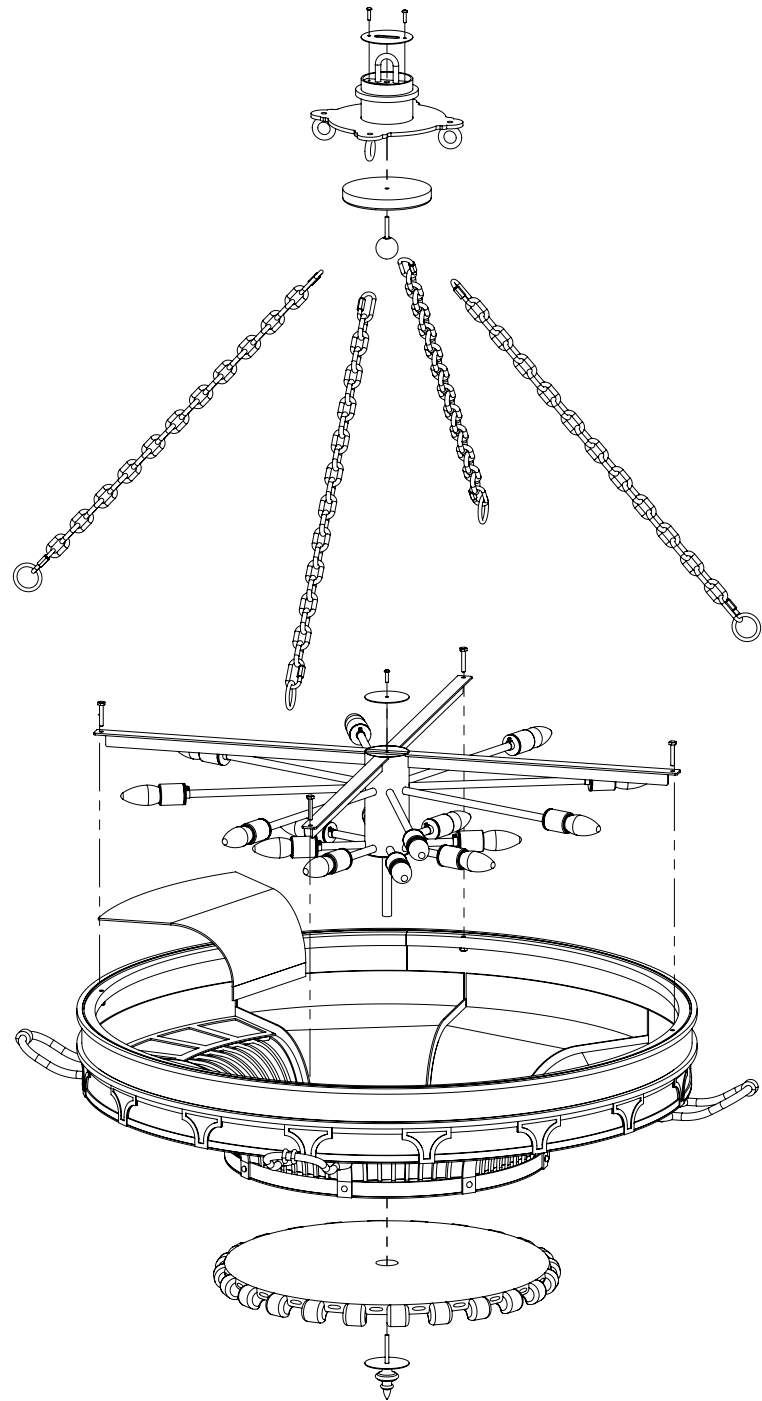

CSTA 0018 CH B