

PERSPECTIVE VIEW

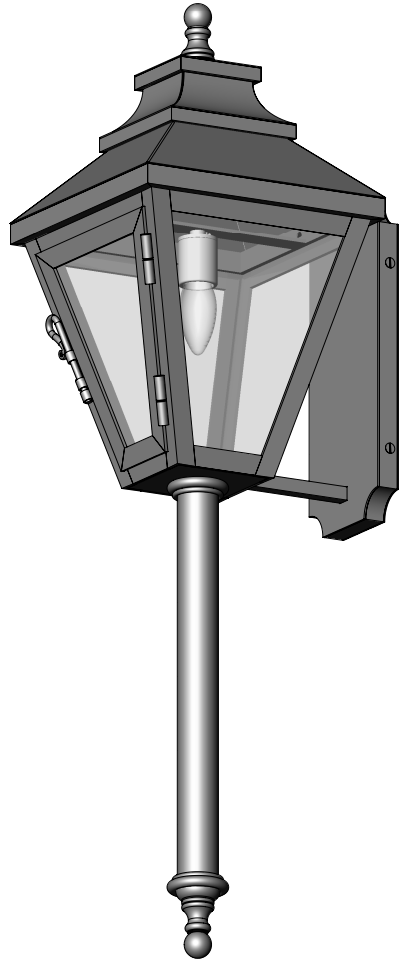

CST 3886 LN

Custom Exterior Lantern

B

WEIGHT: 17 lbs
BACKPLATE: Custom
CHAIN: N/A
LENS: Clear Glass
NO. LIGHTS: 1
BASE: Medium (Porcelain)
FINISH: Natural Black
DRAWING: Ever Roa

21/06/2021

FRONT VIEW

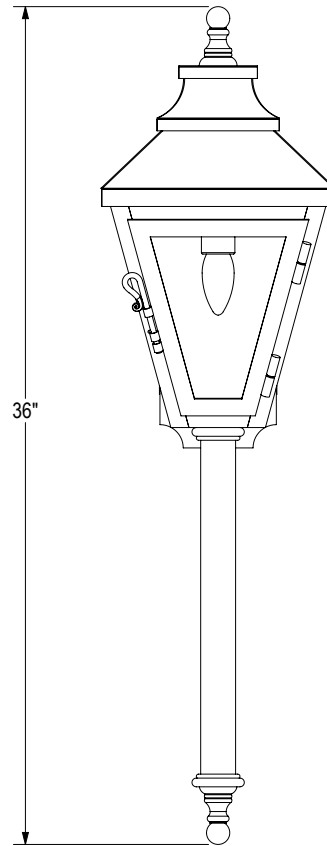

SIDE VIEW

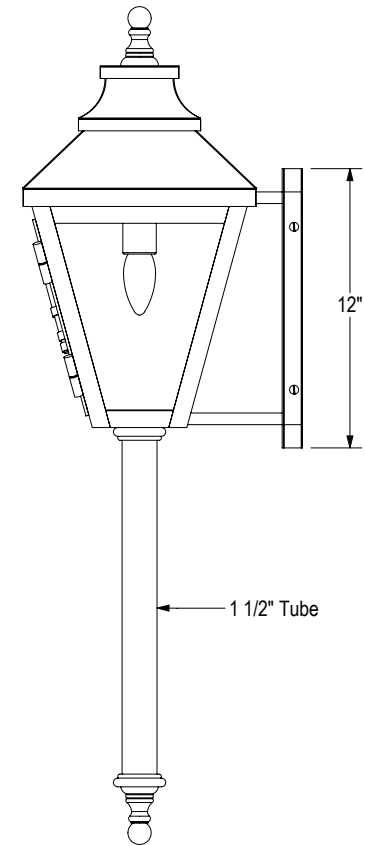

BOTTOM VIEW

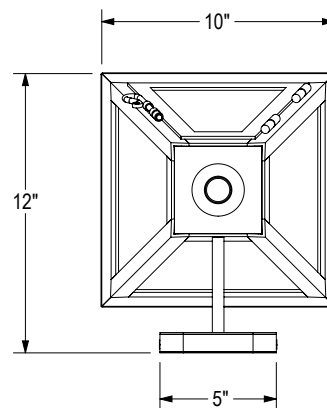

PERSPECTIVE VIEW

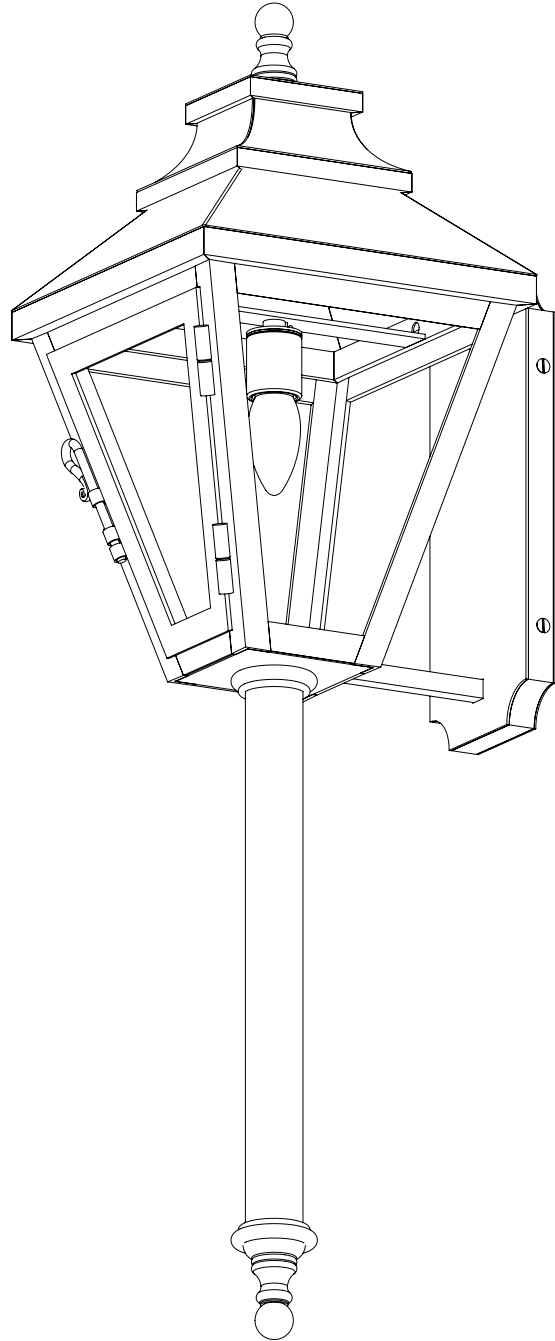

CST 3886 LN B

EXPLODED VIEW

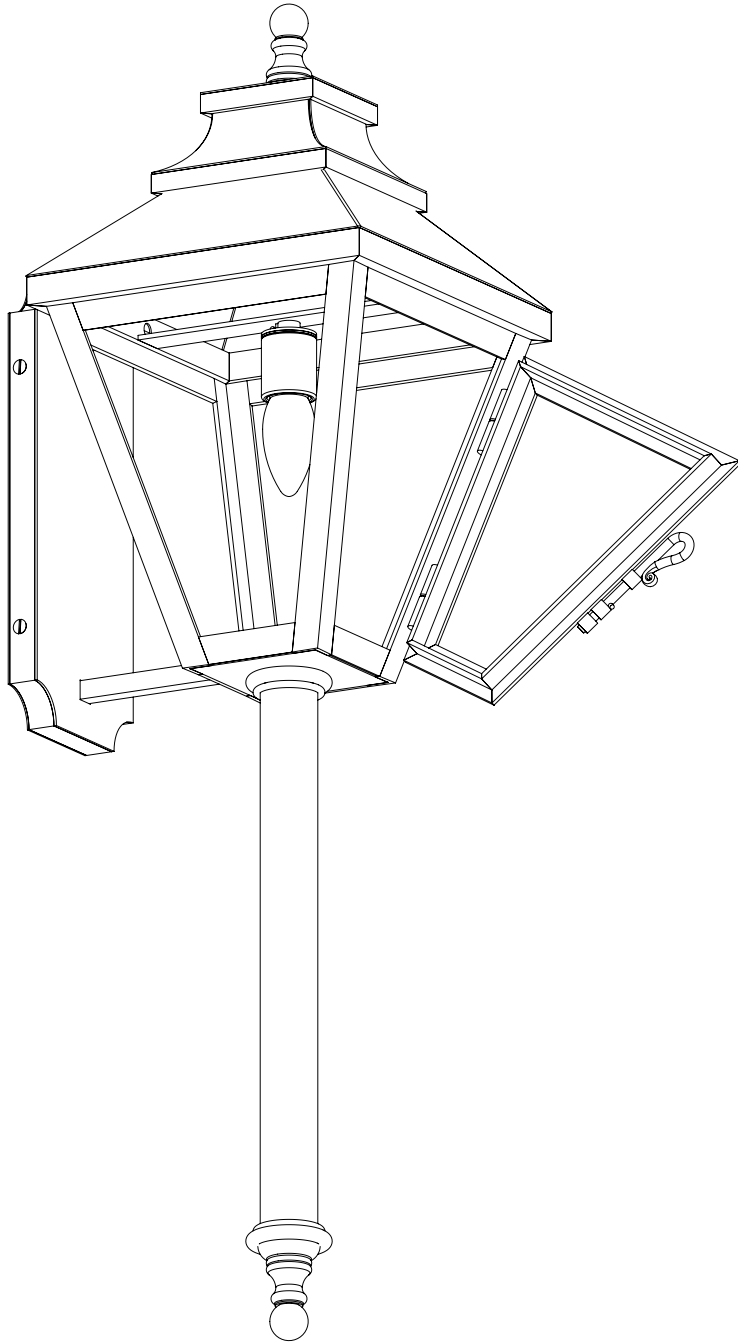

CST 3886 LN B